

NOW
Zero emission
deliveries!



BEEWAY

Electric refrigerated truck 11 m³

8 hrs refrigeration while riding, but also during parking

Over **400 km** autonomy

Up to **895 kg** payload



pRefrigerating bodywork

Made in France

ATP Cemafruid certificate

	Ext.	Int.
Length	3.18 m	3.00 m
Width	1.98 m	1.80 m
Height	2.10 m	1.90 m
Volume	10.26 m³	
Height ground-to-floor	76 cm	
Door	1 rear door	
Lightning	1 ceiling light LED	
Partition thickness	85 mm	
Floor thickness	105 mm	
Included accessories	Stepboard Side guard 3 stop lights 1 year guarantee	
Options	Double rear door Side doors Anchor track Shelves Reversing camera Reversing radar	

Cooling unit

THERMOKING: market leader in the transport refrigeration industry offering reliable and innovative products

Powered by the vehicle's battery or a standard home plug

Cooling in temperatures from 0 to 4°C with ATP certification

Dimensions

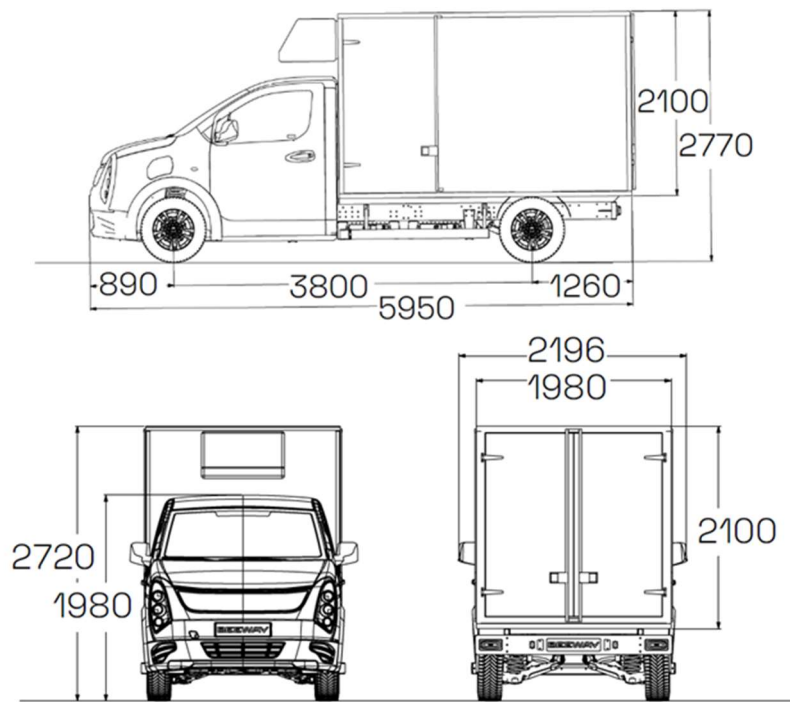

Beeway

Version	Beeway B2	Beeway B3
Battery capacity	82 kWh	123 kWh
Length	5.95 m	
Width	1.98 m	
Height	1.98 m	
Gross Vehicle Weight	3t5	
Net payload (equipped)	895 kg	645 kg
Engine power	110 kW	
Maximum speed	110 km/h	
Autonomy range*	258 km	418 km
AC charge 9 kW**	7.30 hr	11 hrs
DC Charge up to 150 kW**	1 h 30	2 h 20

*Autonomy range calculated for 8hrs of operation with door openings, one WLTP cycle, and depending on the operating conditions and use

** In order to charge between 20 and 80% of the battery in moderate temperature.